

# **Reconstruction of Earthquake Damaged Rural Houses (REDRH)**

## **Operational Guidelines**



**Department of Rural Management and Development  
Government of Sikkim**

<b>Contents</b>	<b>Page No.</b>
<b>1. Introduction</b>	<b>4</b>
<b>2. Assessment of Damage</b>	<b>4</b>
<b>3. Post Earthquake Reconstruction Strategy</b> 3.1 Challenges 3.2 Salient features	<b>5</b>
<b>4. House Design, Estimate, Costing Details and Stock Materials</b> 4.1 House design 4.2 Technical drawings 4.3 Estimate 4.4 Costing details 4.5 Theoretical consumption 4.6 Stock materials	<b>7</b>
<b>5. Beneficiary Prioritization Process</b> 5.1 Prioritization of beneficiaries 5.2 Special Gram Sabha 5.3 Fully and severely damaged CMRHM houses 5.4 Shortfall in achieving Phase-I Cap 5.5 Finalization of Phase-1 beneficiary list 5.6 Publication of final Phase-1 beneficiary list	<b>26</b>
<b>6. House Construction Process</b> 6.1 Implementation mechanism 6.2 Issuing Allotment Order to all beneficiaries 6.3 Stages of house construction 6.4 Release of first installment 6.5 Convergence 6.6 Information, Education and Communication (IEC) activities	<b>29</b>
<b>7. Financial Management</b> 7.1 Annual physical and financial targets 7.2 Fund transfer mechanism 7.3 Fund release and record keeping 7.4 Financial Audit by chartered accountant 7.5 CAG Audit	<b>32</b>
<b>8. Records to be Maintained</b> 8.1 Files 8.2 Registers	<b>33</b>
<b>9. Monitoring, Evaluation and Transparency Safeguards</b> 9.1 Village level 9.2 Block level 9.3 District level 9.4 State level 9.5 Inspection 9.6 Progress reporting	<b>34</b>

9.7 Complaints and grievance redressal 9.8 Transparency safeguards	
<b>10. Capacity Building</b> 10.1 Administrative trainings 10.2 Accounts trainings 10.3 House construction technical trainings	<b>36</b>
<b>11. Activity Calendar</b> 11.1 District, Block and Gram Panchayat level 11.2 RM&DD head-office level	<b>37</b>
<b>Annexure</b>	
I Application Form	<b>39</b>
II Allotment Order from District	<b>40</b>
III Undertaking by Beneficiary	<b>41</b>
IV Sub Voucher Form	<b>42</b>
V Contingent Bill Form	<b>43</b>
VI Fund Utilization Certificate	<b>44</b>
VII Monthly Progress Report from District level	<b>44</b>
VIII Beneficiary Works Register	<b>46</b>

## 1. Introduction:

The Sikkim region falls between Nepal and Bhutan and comprises the lesser active part of the 2500 km stretch of the active Himalayan belt. The seismic hazard scenario of Sikkim Himalaya appears to be underestimated considering its zone IV status in the seismic zonation map of India, unlike zone V for most of the Himalayan front (IS1893, 2002). One cannot overlook the fact that this region is surrounded by Great earthquake occurrences during the past, namely the 1934 Bihar–Nepal earthquake (M 8.3) to the west, the 1897 Shillong earthquake (M 8.7) to the southeast and the 1950 Assam earthquake (M 8.7) to the east (Raju 2007). In the recent past, Sikkim experienced an M 6.1 earthquake on 19<sup>th</sup> Nov, 1980 and more recently on 14<sup>th</sup> Feb, 2006 by an M 5.3 earthquake. Seismic hazard in the Sikkim region is further accentuated due to site amplification which increases from north to south along the Tista and Gangtok lineaments (Nath 2000, 2004). This is attributed to the presence of sedimentary and low grade metamorphic rocks in the Lesser Himalayas.

Sikkim was rocked by an M 6.8 earthquake of intensity VII at 18:10 IST on 18<sup>th</sup> Sept 2011. The earthquake was centered about 64 northwest of Gangtok, Sikkim at a shallow depth of 19.7 km. This 2011 Sikkim Earthquake caused strong shaking in many areas adjacent to its epicenter lasting 30–40 seconds. Although earthquakes in this region are usually interplate in nature, preliminary data suggests the Sikkim earthquake was triggered by shallow strike-slip faulting from an intraplate source within the over-riding Eurasian Plate. Initial analyses also indicate a complex origin, with the perceived tremor likely being a result of two separate events occurring close together in time at similar focal depths. The strongest shaking occurred in Sikkim, with tremors felt in Nepal, Bhutan, Bangladesh and China. In India, the tremors were felt in Assam, Meghalaya, Tripura, parts of West Bengal, Bihar, Jharkhand and as far away as Uttar Pradesh, Rajasthan, Chandigarh and Delhi. This earthquake was followed by three aftershocks occurring at magnitudes of 5.7, 5.1, and 4.6 magnitudes within 30 minutes of the initial earthquake.

## 2. Assessment of Damage:

The state of Sikkim has a fragile ecology being the steepest and highest state in the country, and the third highest landscape globally. It is a mountainous state crisscrossed by narrow valleys and steep cliffs. The young fold mountains are characterized by a weak geology, comprising of sedimentary and low grade metamorphic rocks which are prone to landslides. The state also experiences heavy monsoons with the average annual rainfall being to the tune of 2800 mm. There was colossal collateral damage due to a combination of precipitous terrain, weak geology, fragile ecology and heavy rainfall which amplified the impact of the earthquake creating a multiplier effect resulting in hundreds of natural calamities in the form of landslides, boulder falls and flash floods thereby magnifying the damage to human life and property many times. Dzongu region in North District which was the closest to the epicenter was the worst hit.

In coastal areas, Tsunami poses a formidable post-earthquake threat as was evident during 2011 Japan Earthquake and the 2009 Thailand Earthquake. While in fragile mountain areas like Sikkim, the major damage was caused by the shower of landslides and boulder falls. Post earthquake fresh landslides in North Sikkim are visible as brown scars in the satellite map of NASA. The National Remote Sensing Centre, ISRO, Dept of Space also identified 354 new landslides post earthquake using remote sensing images. The increasing frequency and

intensity of earthquakes with growing hazard due to rapid urbanization has renewed the urgency in improving the preparedness and making the infrastructure earthquake resistant. The rural housing sector has long been a priority sector of the government and has received sizeable public investments. It is an important social infrastructure, providing safety, identity and dignity to the owner. Presently there are a total of 92,000 rural households with a population of 4.5 lakh in the state as per Census of India, 2011.

The assessment report of fully and severely damaged 12,548 rural and 478 urban houses was received from LR&DMD vide letter no 22/LR&DMD dated 15/11/2011. The breakup of the total 12,548 rural houses fully and severely damaged is placed below.

**Table 1**

S. No.	Type of damage	North	East	South	West	Total
1	Fully damaged	516	956	446	625	2,543
2	Severely damaged	4,500	3,077	857	1,571	10,005
3	Total	5,016	4,033	1,303	2,196	12,548

*Source: Land Revenue and Disaster Management Department, Government of Sikkim*

### 3. Post Earthquake Reconstruction Strategy:

This earthquake is a wakeup call to ensure that human lives and infrastructure are safeguarded against extensive damage in future earthquakes. The goal of this program is to ensure adoption of earthquake resistant house construction techniques thereby improving the preparedness of the state to handle such disasters and reducing damages and significantly cutting down public expenditure in construction of new houses in future.

**3.1 Challenges:** This project faces the following challenges

- 1. Social challenge:** Out of 12,548 fully/severely damaged houses, 7,972 houses will be taken up under this project following a transparent, non-arbitrary and just process which should be able to withstand the test of independent scrutiny. This prioritization approach will result in non-coverage of 4,576 households, which will need strong social, inter personal and IEC skills to ameliorate.
- 2. Physical challenge:** Constructing these 7,972 houses which are scattered in the highest and steepest mountain terrain with existing manpower (who are already implementing ongoing programs) is a formidable task at hand.
- 3. Economic challenge:** The unit cost of Rs 4.89 lakh per house is based on a standard unit cost. While construction is being undertaken in 2012-13, the estimate is based on SPWD SOR of 2006. While certain relaxations as a onetime dispensation are being explored, completing these houses without compromising on the design, construction quality, budgetary ceiling and time frame will need strong commitment, determination and team work.

### 3.2 Salient features:

- **The design of the house** will be RCC frame with a slab roof and having a plinth area of 605 square feet. However, in Dzongu and Lachen Mangshila Constituencies and two Gram Panchayats in West District namely Karzi Mangnam GPU and Dhoopi Narkhola GPU, option of GCI roofing will be provided. In other remote areas, similar relaxation of the house design may be permitted, provided prior approval of the District Level Committee is taken.
- **The costing of Rs 4.89 lakh per house** is based on standard unit cost
- **The implementation mechanism** shall be Departmental to ensure fast grounding and completion of this project which is a relief related NC activity.
- **Beneficiary selection in Special Gram Sabha by prioritizing 7,972 households of the total 12,548 whose houses were fully/severely damaged**
- **Centralized purchase of Steel rods (TMT bars) of 500d earthquake resistant specification and cement** is being explored from the head office. Other stock materials like bricks, non-stock material (stone, timber, sand etc) and labour has to be arranged for locally.

The post-earthquake strategy for the rural housing sector would be to construct earthquake resistant, new and improved RC frame houses for those households whose houses have been fully and severely damaged. The unit cost of these houses is Rs 4.89 lakh as per SPWD SOR 2006, and it incorporates reasonably good earthquake resistant design. More details on the house design, estimate and construction materials are provided for in Chapter 4.

For selection of the 7,972 rural houses out of the total 12,548 fully and severely damaged houses, an elaborate transparent mechanism has been designed. The initial list of ex-gratia payments released to fully and severely damaged house will be digitized and further cross checked in a Special Gram Sabha. This double verification is needed since during ex-gratia payment release, the government machinery was also engaged in rescue and relief operations simultaneously and complete field verification was not possible at that time. Now during post earthquake long term reconstruction, better planning is possible. Also prioritization of 7,972 rural houses in Phase-I out of the total 12,548 fully and severely damaged houses will be done by giving priority to poorer households in a Special Gram Sabha following detailed transparency safeguards which are detailed in Chapter 5.

Chapter 6 provides details of the process to be followed for house construction. All the Phase-1 beneficiaries will be provided an orientation about the program and issued an “Allotment Order”. They will also need to give an Undertaking, and implementation will be taken up Departmentally with funds released to the AE in four installments after achieving pre-determined benchmarks. Also they will need to lift stock materials from the RM&DD store at Tadong for North and East Districts and Jorethang Store for South and West Districts. The financial procedure followed for fund release from State to District to Block will be similar to the Chief Minister’s Rural Housing Mission (CMRHM).

The details of the financial management and records to be maintained at the Block and District level are indicated in Chapters 7 and 8. Chapter 9 provides details of the monitoring, evaluation and transparency safeguards which need to be strictly adhered to. Chapter 10 indicates the need

for administrative, accounts and technical trainings. While, Chapter 11 details the activities to be initiated, the Responsible Officer, Supervising Officer as well as the deadline. In the end, various Annexures have been appended.

These guidelines have been prepared in a participatory manner with several stages of consultations with the various stakeholders and experts. The abstract of the consultations conducted is placed below:

- 21<sup>st</sup> Oct, 2011 – Meeting with various stakeholders and experts from People’s Science Institute, Dehradun in RMDD Conference Hall.
- 24<sup>th</sup> Oct, 2011 – Meeting with various stakeholders and experts from PERT, NIDM in Gangtok Municipal Corporation, Conference Hall.
- 22<sup>nd</sup> Nov, 2011 – Inhouse departmental meeting with experts Mr. and Mrs Desai from National Centre for People’s Action on Disaster Preparedness, Ahmedabad.
- 10<sup>th</sup> Jan, 2012 – Meeting with District Collectors in Chintan Bhawan Committee Room.
- 20<sup>th</sup> Feb, 2012 – Meeting with ADC(Dev) in Chintan Bhawan Committee Room.
- 16<sup>th</sup> Mar, 2012 - Draft operational guidelines were presented and discussed thread bare with Secretary-LR&DMD, DCs, ADCs(Dev) and BDOs in RM&DD Conference Hall.
- 20<sup>th</sup> Mar, 2012 – Improved operational guidelines circulated for final comments.
- 28<sup>th</sup> April, 2012 – Kickoff workshop
- 21<sup>th</sup> May, 2012 – Technical Training workshop of all JE/AE

#### **4. House design, estimate, costing details and construction materials:**

Design of the house is same as Model ‘C’ of CMRHM which has a slab roof with 9 columns (12inches x 12inches) and 4inches slab with *chajja* of 2 feet 9 inches cantilever.

##### **4.1. Basic minimum standards or core design**

The house must adhere to certain **Basic Minimum Standards** of

- **Size:** Total floor area should not be less than 605 sq feet
- **Foundation:** RCC with 9 columns (1feet x 1 feet) and RCC beams of (1feet x 1 feet)
- **Walls:** should be half brick walling over RCC frame
- **Flooring:** should be Cement Concrete
- **Roofing:** RCC Slab 4 inches thick. *Chajja* or cantilever has projection of 2 feet 9 inches
- **Sanitation:** Minimum one toilet with the same minimum criteria as indicated for house (as above) along with septic tank

In remote areas, limited relaxation on the house design will be permitted, provided prior approval of the concerned District Level Committee is taken. However, even in this case, the plinth area of 605 square feet and RCC frame (columns and beams) is mandatory. Option of using mild steel instead of wood for construction of windows and ply board/block board instead of sal wood for door panel will also be provided. This has been permitted since in these remote locations, head load costs will be very high, which has not been provided for in the estimate.

## 4.2 Technical Drawings

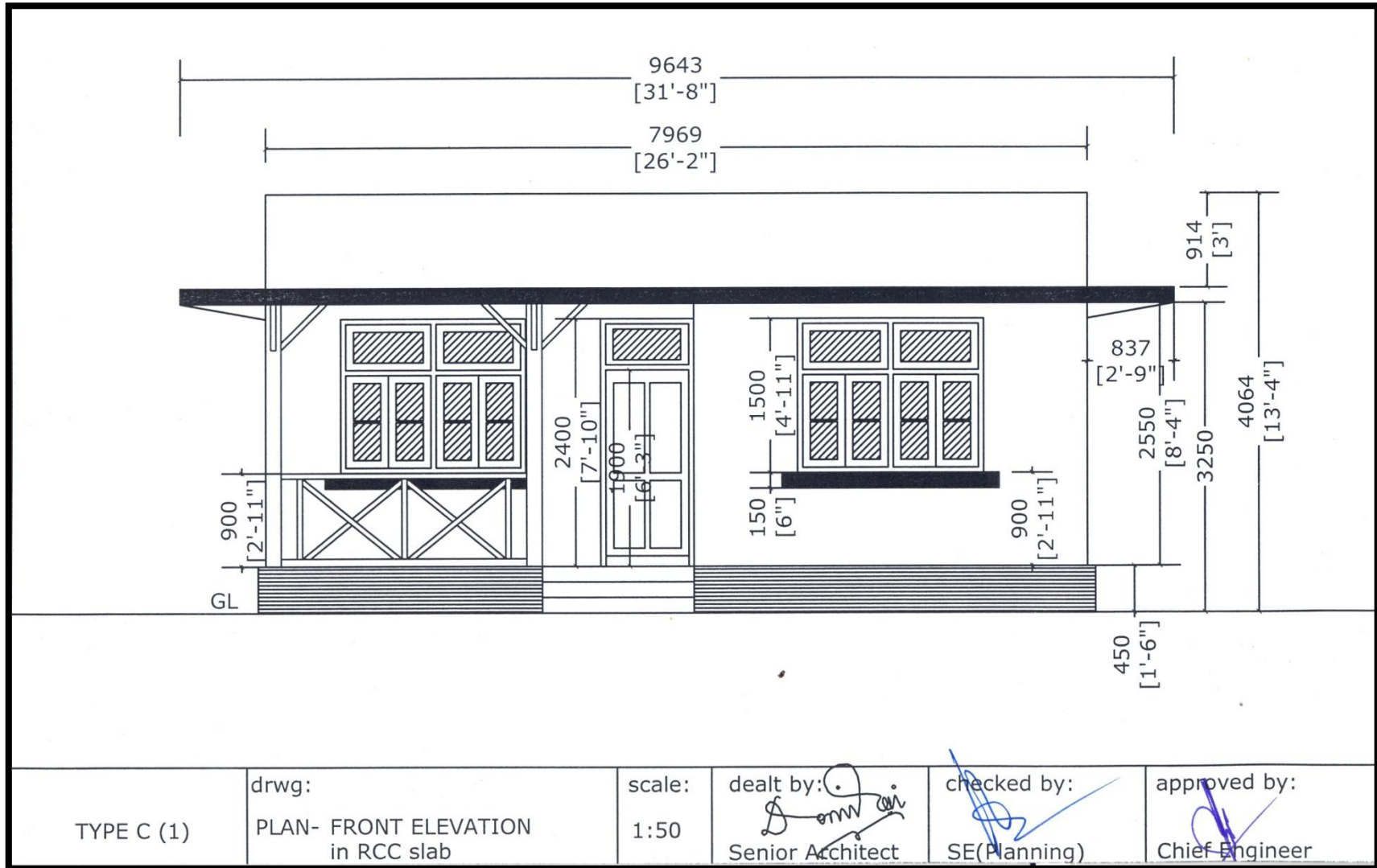



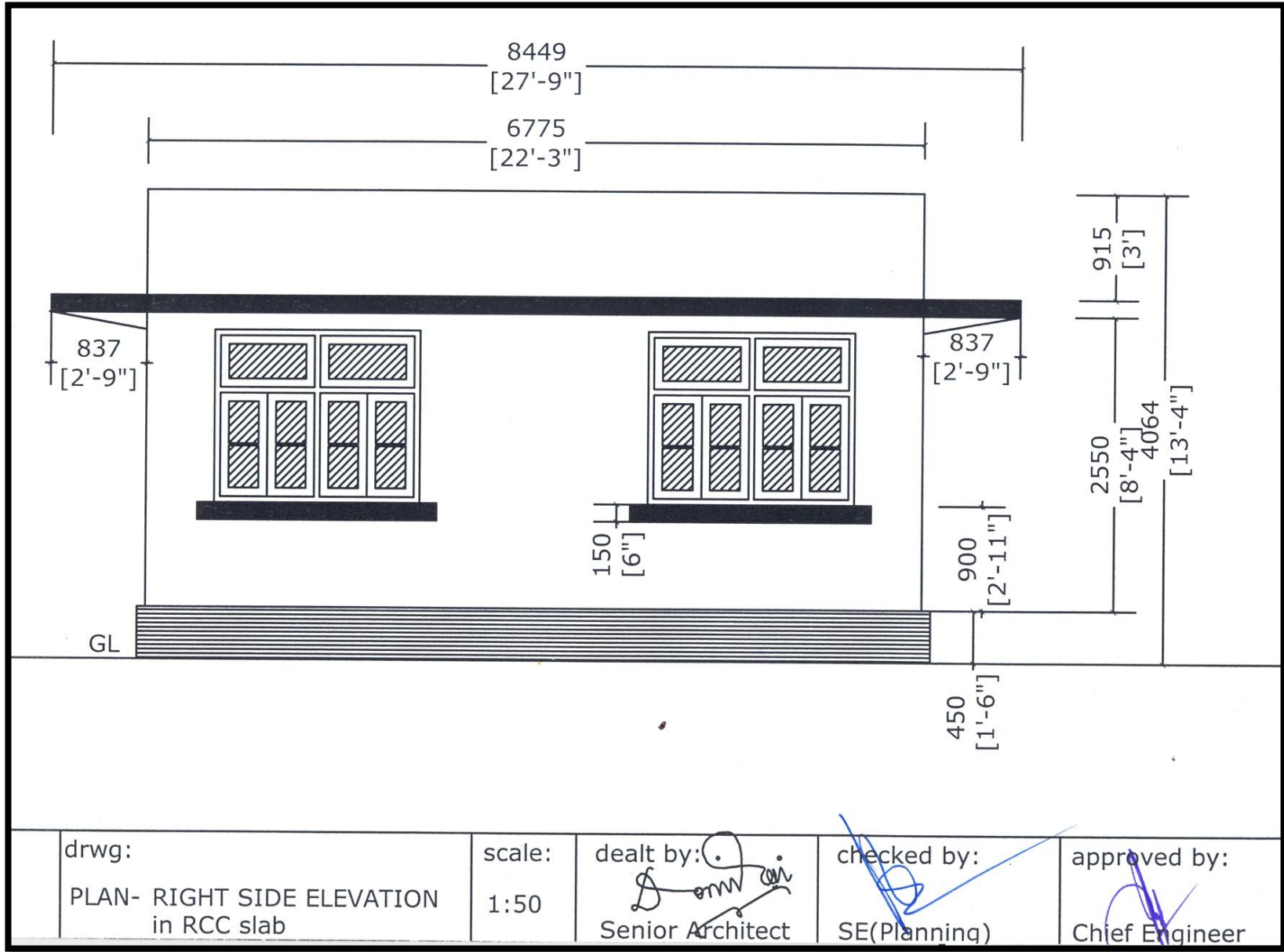

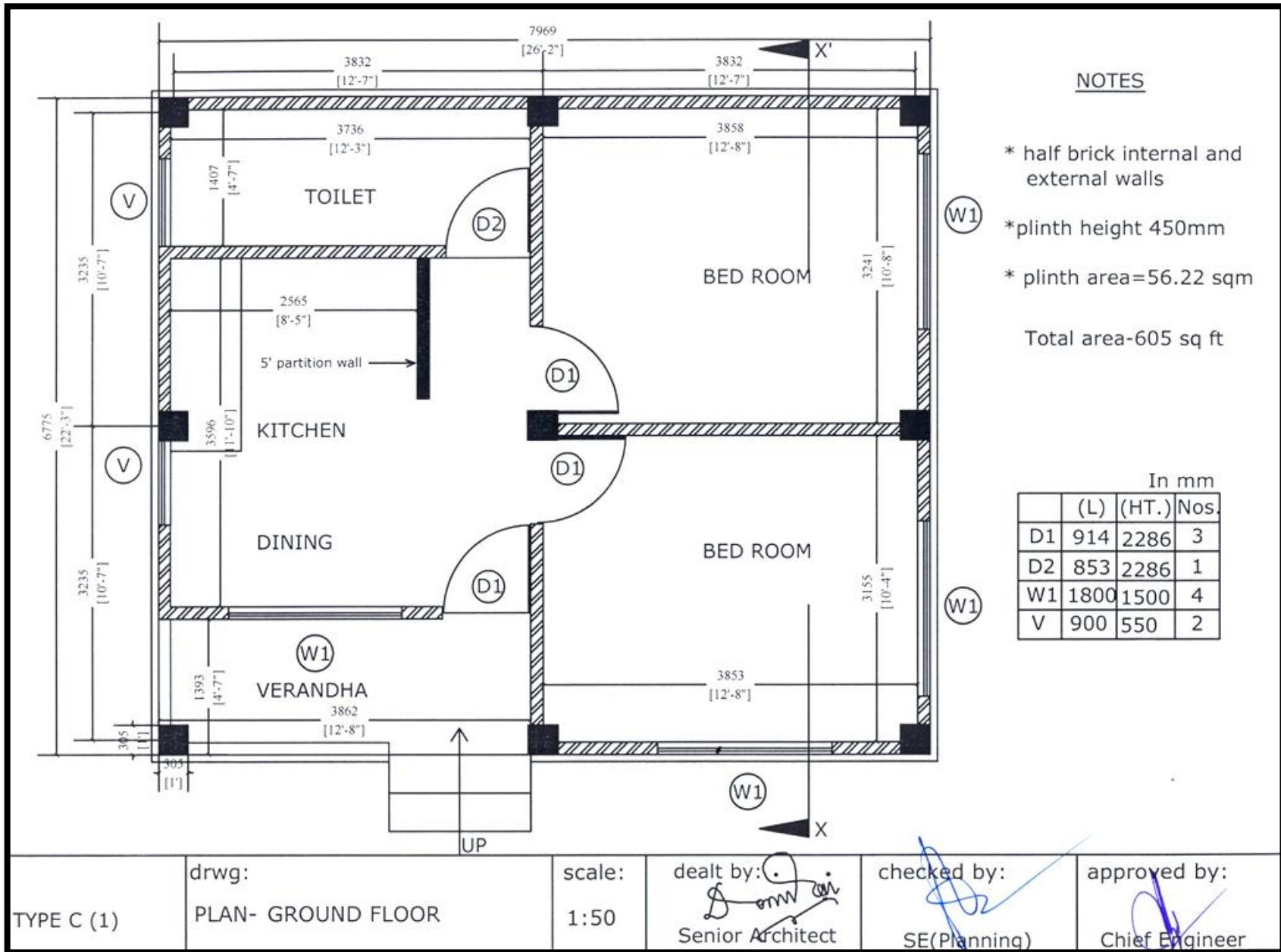

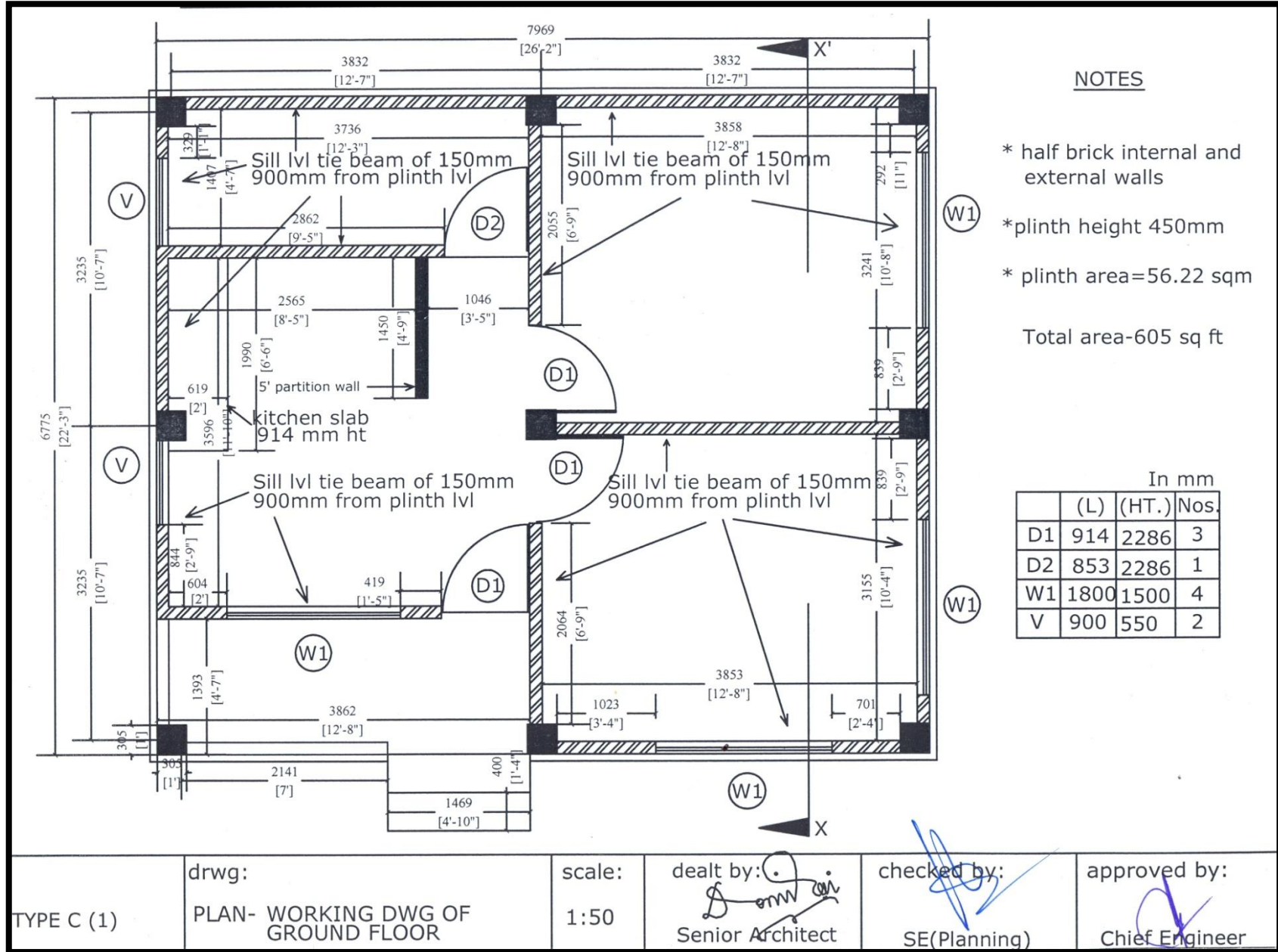



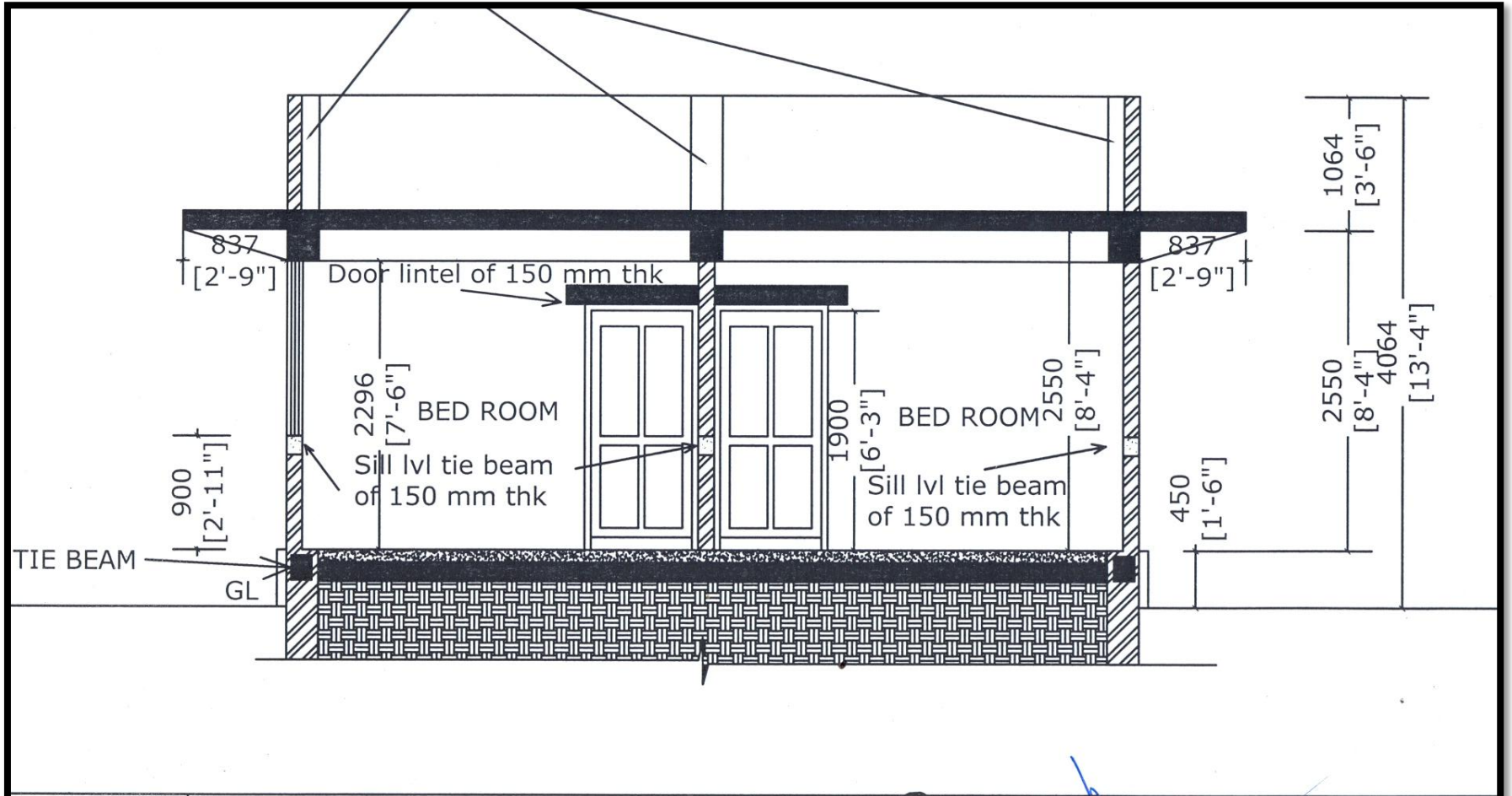





PE C (1)	drwg: PLAN- SECTION XX' in RCC slab	scale: 1:50	dealt by:  Senior Architect	checked by:  SE(Planning)	approved by:  Chief Engineer
----------	---	----------------	--	--	---

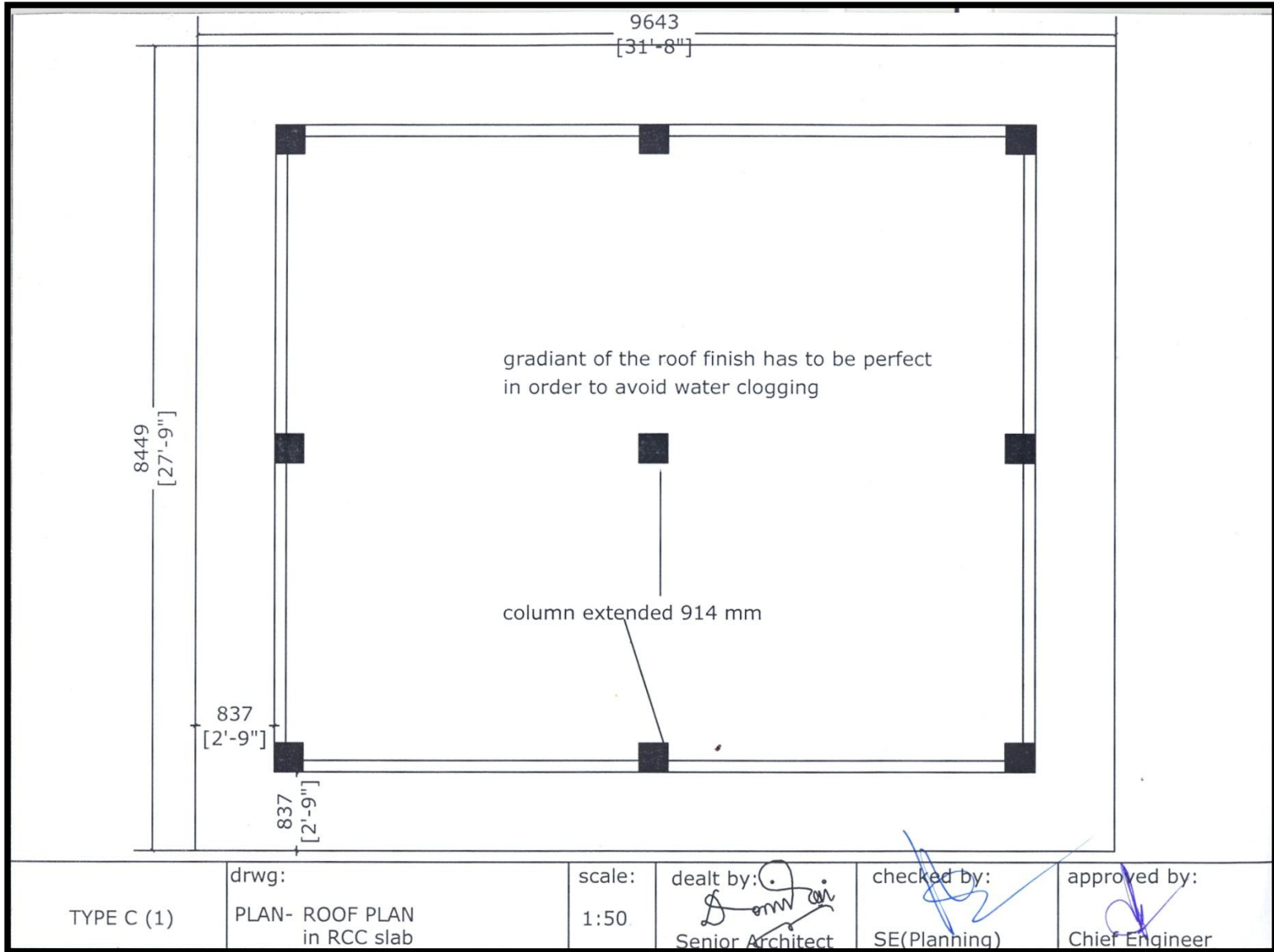

## Details of Reinforcement of Slab

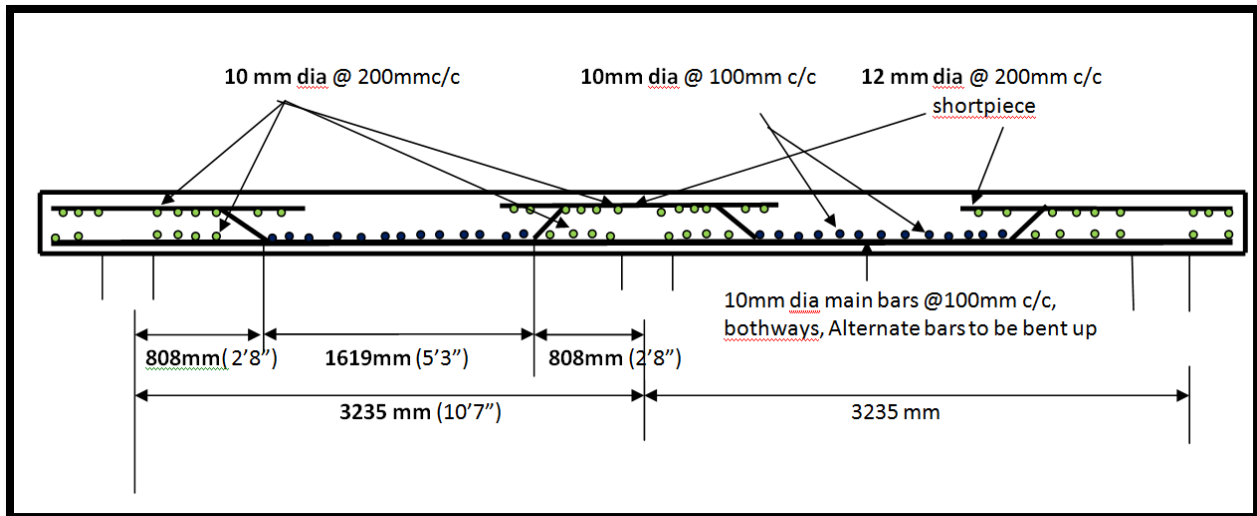
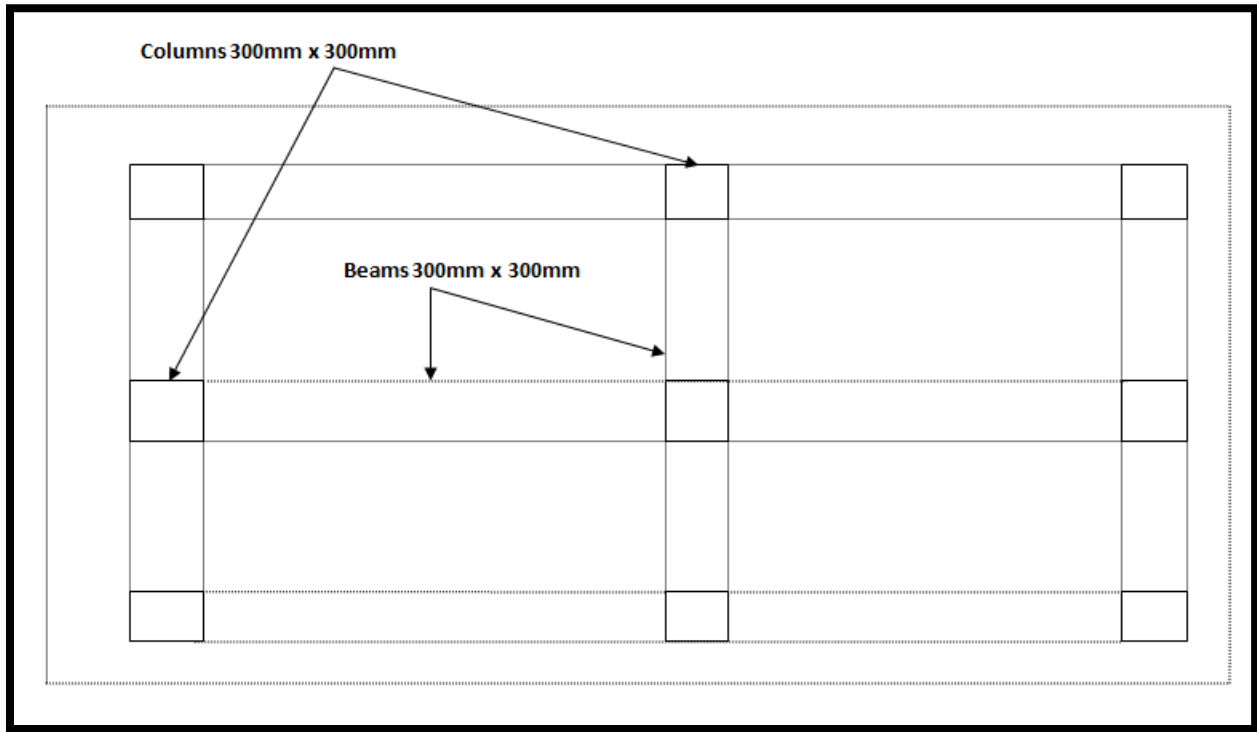

## Details of Lintel Beam

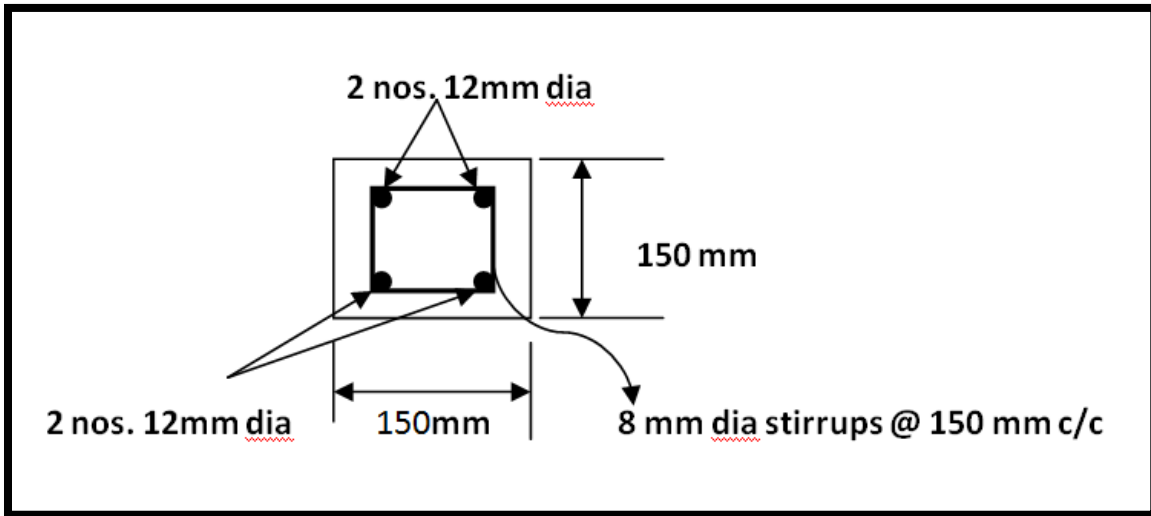

## Details of Column and Beam Joint (End)

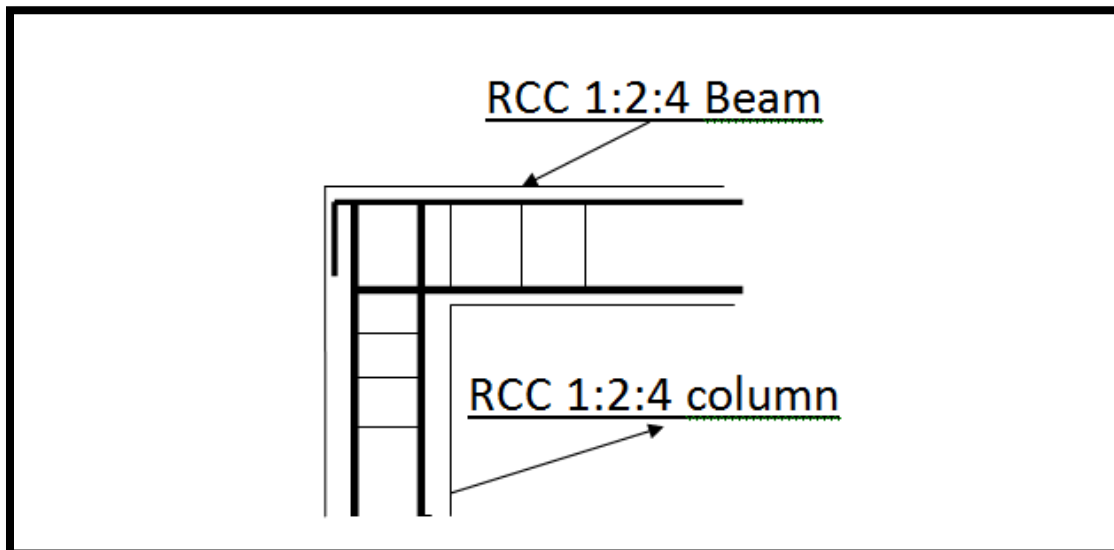

## Foundation Details

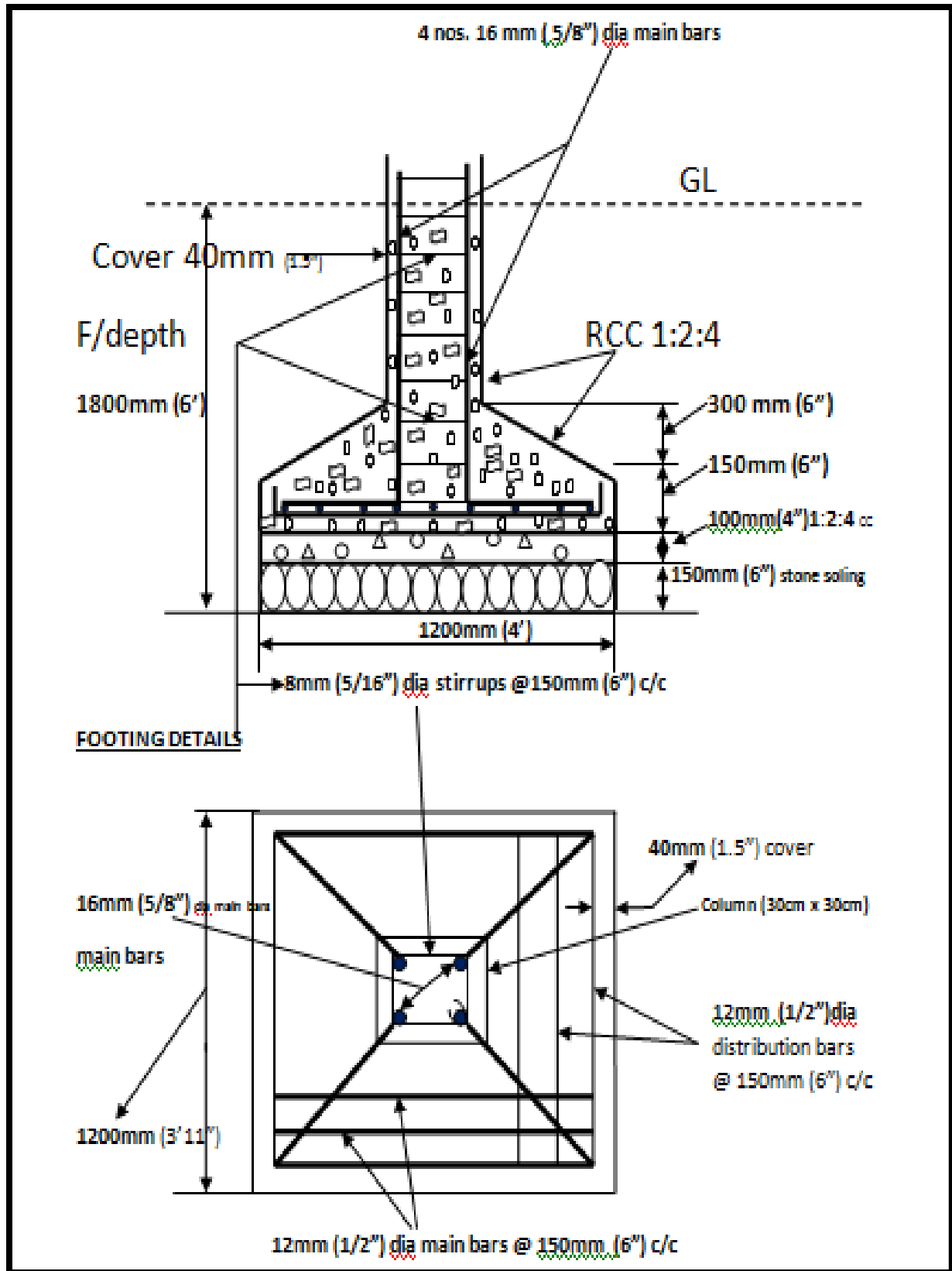



## Details of Tie Beam and Column Joint

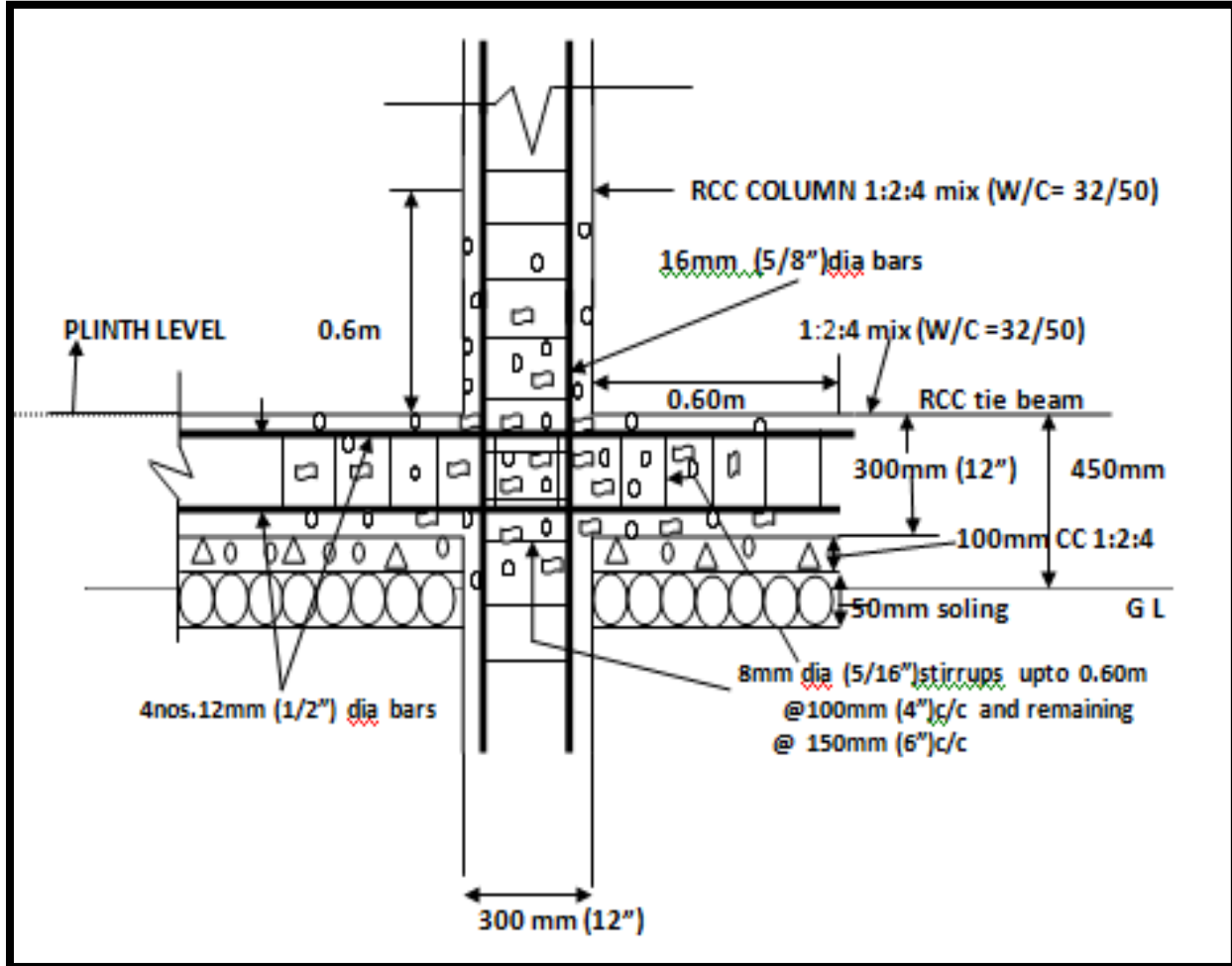

## Details of Beam

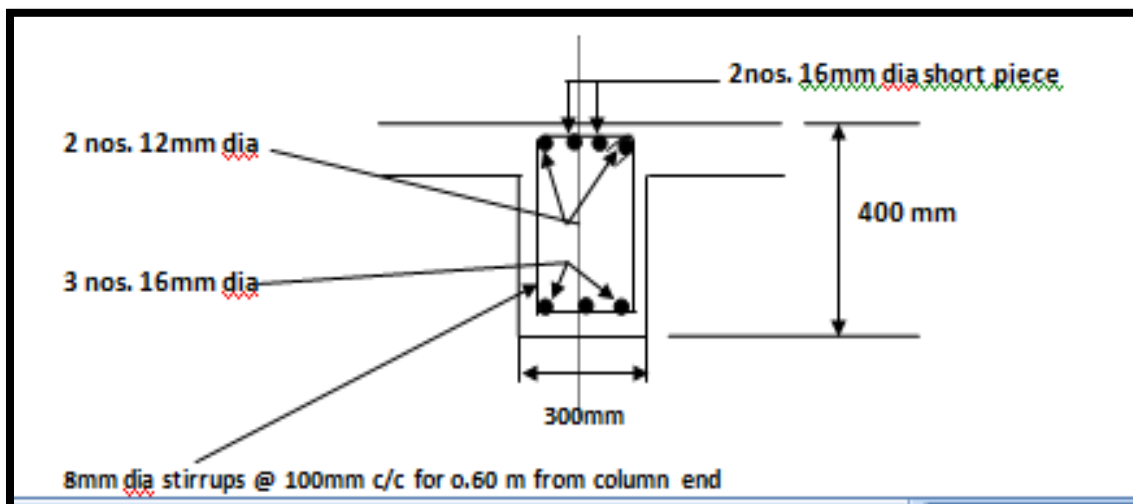

## 4.3 ESTIMATE

### Reconstruction of Earthquake Damaged House

S.N.	Items of Work	No.	Length (M)	Breadth (M)	Height (M)	Quantity	Rate	Amount
1	Hill cutting works and Site levelling					1 job	L.S	5000
2	Earthwork in excavation in all kinds of soil in foundation trenches i/c. dressing of all sides, watering, ramming i/c. disposal of excavated earth upto 30m lead and lift upto 1.5m, disposed earth to be levelled and neatly dressed.							
	columns	9	1.20	1.20	1.80	23.33		
	Tie Beam (Long)	3	7.07	0.30	0.10	0.64		
	Tie Beam (Short)	3	5.88	0.30	0.10	0.53		
	Steps	1	1.50	0.90	0.25	0.34		
						<b>24.83</b>	96.19 /Cum	2389
3	Providing and laying stone Soling in building works with clean hard selected stones, all complete.							
	columns	9	1.20	1.20	0.15	1.94		
	Tie Beam (Long)	3	7.07	0.30	0.15	0.95		
	Tie Beam (Short)	3	5.88	0.30	0.15	0.79		
	Rooms	4	3.55	2.90	0.15	6.18		
	Steps	1	1.50	0.90	0.15	0.20		
						<b>10.07</b>	351.51 /Cum	3541
4	Providing and laying in position cement concrete of 1:3:6 mix including compacting curing etc. all complete.							
	columns	9	1.20	1.20	0.10	1.30		
	Tie Beam (Long)	3	7.07	0.30	0.10	0.64		
	Tie Beam (Short)	3	5.88	0.30	0.10	0.53		
	Rooms	4	3.55	2.90	0.10	4.12		
	Steps	1	1.50	0.90	0.10	0.14		
						<b>6.71</b>	2960.70 Cum	19880
5	Providing and laying in position 1:2:4 mix of reinforced cement concrete excluding the cost of formwork, finishing and reinforcements.							

	Column base	9	1.20	1.20	0.15	1.94			
	column pyramid	$9 \times [(1.2)^2 + (0.30)^2 + 4 \times \{(1.2 + 0.30)/2\}^2] \times 0.30/6$				1.70			
	columns	9	0.30	0.30	4.40	3.56			
	Tie Beam (Long)	3	7.07	0.30	0.30	1.91			
	Tie Beam (Short)	3	5.88	0.30	0.30	1.59			
	Beams (Long)	3	7.07	0.30	0.30	1.91			
	Beams (short)	3	5.88	0.30	0.30	1.59			
	Slab	1	9.64	8.45	0.10	8.15			
	Sill level tie beam	1	7.07	0.15	0.15	0.16			
		1	5.88	0.15	0.15	0.13			
		1	3.53	0.15	0.15	0.16			
		1	2.12	0.15	0.15	0.05			
		1	2.00	0.15	0.15	0.05			
		1	2.74	0.15	0.15	0.12			
		1	5.39	0.15	0.15	0.12			
	Door lintel	4	1.20	0.15	0.10	0.07			
						<b>23.21</b>	3090.48 /Cum	71719	
6	Supplying, bending and placing in position for steel reinforcement in all RCC works including cost of binding wires, all complete.	23.21		@ 120 kg/cum		<b>27.85</b>			
	Main bars			85%		<b>23.67</b>	4119.55 /Qtl.	97512	
	8mm dia bars for stirrups			15%		<b>4.18</b>	4172.2 /Qtl.	17428	
7	Formwork for all RCC members					<b>1 job</b>	L.S.	15000	
8	P/L first class brickwork in half brick thick in superstructure of standard size bricks with 1:4 cement mortar (1cement & 4clean coarse sand) as per direction of Engineer in charge i/c curing etc.all comp.	1	7.07		2.55	18.03			
		1	5.88		2.55	14.99			
		1	2.30		2.85	6.56			
		2	3.55		2.55	18.11			
		2	2.74		2.85	15.62			
		2	2.95		2.55	15.05			
		1	1.85		2.55	4.72			
		2	9.64		0.90	17.35			
		2	8.24		0.90	14.83			
						<b>A</b>	<b>123.43</b>		
	Deduction W1	4	1.80		1.50	10.80			
	V	1	0.90		0.55	0.50			
						<b>B</b>	<b>11.30</b>		
						<b>A - B</b>	<b>112.14</b>	428.90 /Sqm	48096
9	P/L 12 mm thick cement plaster								

	of 1:4 mix in single coat i/c finishing even and smooth and curing complete.							
	V.I. No. 8 columns	2	x	112.14		224.27		
		6	(2x0.30+2x0.175)		2.55	14.54		
		1	(1x.30+3x.175)		2.55	2.10		
		1	(3x0.30+1x0.175)		2.55	2.74		
	Beams	1	4 x 0.30		2.55	3.06		
		3	7.96	(2 x 0.30+ 0.175)		18.51		
		3	6.78	(2 x 0.30+ 0.175)		15.76		
		2	8.20		0.45	7.38		
		2	7.00		0.45	6.30		
		3	1.50		0.15	0.68		
		3	1.50	0.30		1.35		
	steps (sides)	2	1.50		0.90	2.70		
		2	1.50		0.60	1.80		
		2	1.50		0.30	0.90		
						<b>302.09</b>	71.91	Sqm
								21724
10	P/L 40mm thick 1:2:4 cc flooring with floating coat of neat cement to give smooth surface in not exceeding 2sqm i/c cost of glass strips and curing etc. all comp.							
	Bed room	1	3.98	3.24		12.90		
	Bed room	1	3.85	3.15		12.13		
	Toilet/Bathroom	1	3.50	1.79		6.27		
	Kitchen	1	3.60	3.20		11.52		
	Verandah	1	3.90	1.40		5.46		
						<b>48.27</b>	185.11	sqm
								8935
11	Providing, fitting and fixing of dressed sal timber in all types of frames complete. D2	1x2	0.10	0.075	2.40	0.11		
		1x1	0.10	0.075	1.05	0.02		
		3x2	0.10	0.075	2.10	0.03		
		3x1	0.10	0.075	1.00	0.01		
	W1	4x3	0.10	0.075	1.95	0.18		
	V	4x3	0.10	0.075	1.50	0.14		
		2x2	0.10	0.075	0.90	0.03		
		2x2	0.10	0.075	1.05	0.03		
						<b>0.54</b>	25647.75	cum
								13841
12	Providing, fitting and fixing in position of fully panelled shutters	1		1.00	2.4	<b>2.40</b>		

	in doors of Champ timber or equivalent i/c steel butt hinges screws 12mm thick panels etc. all complete. (40mm thick)	3		0.9	2.10	5.67	1743.65 sqm	14072
						<b>8.07</b>		
13	Providing, fitting and fixing in position of fully glazed shutters in windows of Champ wood or equivalent i/c steel butt hinges, screws 3mm glass panes of modi guard or equivalent etc., all complete. (30mm thick)	4		1.80	1.50	10.80	1100.83 /sqm	12979
		2		0.9	0.55	0.99		
						<b>11.79</b>		
14	Providing, fitting and fixing MS handles 125mm size with necessary screws etc. complete.	4x2				8	25.52 /No.	307
		4				4		
						<b>12</b>		
15	Providing, fitting and fixing MS 250x16mm size sliding door bolts with nuts and screws etc. complete.	3				3	155.18 /No.	466
16	Providing, fitting Tower bolt MS 200x100mm with necessary screws etc. in doors, complete.	4x2				8	40.34 /No.	323
17	Providing, fitting Tower bolt MS 150x100mm with necessary screws etc. complete.	4x2				8	40.34 /No.	323
18	White washing, Distempering and painting works					<b>1 job</b>	LS	8000
19	Providing, fitting and fixing white vitreous china water closet (W.C) squatting pan (Indian type) 530 mm size with 100mm SCI (Sand cast iron) P or Strap, 10ltr low level flushing cistern with fittings, CI brackets, 32mm flush pipe with fittings and clamps, 20mm overflow pipe, cutting and making good the wall and floor etc complete. Long type or Orissa type pan. HINDWARE CAT NO. 20004.	1				1	2919.47 /No.	2920
20	P/L CRSM in 1:4:8 cc (1cement, 4 sand, 8 clean hard graded stone chips of size 40mm & down) i/c bond stone, through stone of size 150mmx150mmx 450mm manufactured in 1:4:8 and curing etc. complete as per direction of Engineer in charge excluding the cost of carriage of materials							
	Plinth wall	2	8.20	0.45	0.45	3.32		
	Plinth wall	2	7.00	0.45	0.45	2.84		

	steps	1	1.50	0.90	0.15	0.20	1584.73 /Cum	10397
		1	1.50	0.60	0.15	0.14		
		1	1.50	0.30	0.15	0.07		

21	Provision for U shaped drain		L.S.	10000
22	Provision for Hand rails in Verandah		L.S.	5000
23	Carriage of stock and non stock materials		L.S	20000
24	Provision for internal water supply & Sanitation		L.S	10000
25	Provision for septic tank		L.S.	15000
26	Provision for Electrification		L.S	10000
			<b>Total</b>	<b>444852</b>
			<b>Say,</b>	<b>444900</b>
			Protective work	45000
			<b>GRAND TOTAL</b>	<b>489900</b>

**( RUPEES FOUR LAKHS EIGHTY NINE THOUSAND AND NINE HUNDRED) ONLY**

**Estimate has been prepared as per SPWD Schedule of Rates – 2006**

**4.4 Costing details: (Abstract of Cost)**

Sl. No.	Particulars of work	Estimated cost in Rs.
1.	Hill Cutting and Protective work	50,000.00
2.	Foundation work upto Plinth Level	1,00,883.00
3.	Superstructure (Column, Beams, Slab, Brick walls)	2,06,803.00
4.	Flooring work (Cement Concrete 1:2:4)	8,935.00
5.	Doors and windows	42,311.00
6.	White washing, Distempering & Painting works	8,000.00
7.	Carriage of stock & Non Stock materials	20,000.00
8.	Internal Water Supply & Sanitation	12,920.00
9.	Septic tank	15,000.00
10.	Internal Electrification	10,000.00
11.	U shaped Drain	10,000.00
12.	Wooden Railing in Verandah	5,000.00
<b>Total</b>		<b>4,89,852.00</b>

#### 4.5 Theoretical Consumption of Stock Material

S. No.	Material Requirement	Quantity	Unit
1	Cement	300	Bags
2	TMT Bars	26	Quintals

#### Requirement of 16mm, 12mm, 10mm and 8mm Bars

	Nos.	Length	Total Length			
<b>16 mm dia Bars (TS)</b>						
Column	9 x 4	16'3"	585	ft		
Roof beam						
Bottom	3x3	31'6"	283.5	ft		
shortpiece	3x2	6'	36	ft		
shortpiece	3x2x2	6'	72	ft		
C/ B Bottom	3x3	27'6"	247.5			
shortpiece	3x2	6'	36	ft		
shortpiece	3x2x2	6'	72	ft		
			1332	ft		
			67	ft		
			1399	ft		
			426	mtr		
		@	1.58	kg/mtr	674	kg

<b>12mm dia (TS)</b>				
Plinth Beam	3 x 4	27'	324	ft
Plinth Beam	3x4	22'	264	ft
Top	3x2	31'6"	189	ft
top	3x2	27'6"	165	ft
column base	9x2x8	4'3"	612	ft
Lintel	4x4	4'	64	ft
5% lapping & wastage			1618	ft
			80.9	ft
			1698.9	ft
			517.96	mtr
			<b>@ 0.89 kg/mtr</b>	<b>461 kg</b>

<b>10mm dia (TS)</b>				
Slab	@ 200 mm c/c			
Long	45	33'	1485	ft
Cross	50	29'	1450	ft
Short piece				
	45	6'	270	ft
	2 x 45	6'	540	ft
	50	6'	300	ft
	2 x 50	6'	600	ft
Sill level Beam				
	1x4	30'	120	ft
	1x4	25'	100	ft
	2 x 4	14'	112	ft
	1x4	8'	32	ft
	2 x 4	10'	80	ft



	1x4	19'	76	ft
5% wastage & lapping			<b>5165</b>	<b>ft</b>
			<b>258.25</b>	<b>ft</b>
			<b>5423.25</b>	
			<b>1653.43</b>	<b>Mtr</b>
		<b>@</b>	<b>0.62 kg/mtr</b>	<b>1025 kg</b>

<b>8 mm dia (TS)</b>				
stirrups				
column	9 x 25	3'8"	825	ft
plinth Beam	3 x 52	3'8"	572	ft
	3 x 44	3'8"	484	ft
Roof Beam	3 x 52	5'2"	806	ft
	3 x 44	5'2"	682	ft
Window sill level beam	166	2'	332	ft
			3701	ft
			1128.35	mtr
			<b>@</b>	<b>0.39 kg/mtr</b>
			<b>440</b>	<b>kg</b>
			<b>TOTAL</b>	<b>2600 kg</b>

#### 4.6 Stock materials

- Stock materials** of prescribed quality will be available at cheaper rate when procured in a centralized manner from STSC or from reputed companies at subsidized rates as a part of their Corporate Social Responsibility. For a unit house, 26 quintals of rod and 300 bags of cement will be needed. Construction using TMT bars of 500d specification with earthquake resistant features (which is not readily available locally) will result in a strong and good quality house. Cement being a perishable commodity with a limited shelf life, managing the logistics of centralized purchase is still being worked out. This stock material will be issued from Tadong store for North and East Districts and from Jorethang store for South and West Districts.

## 5. Beneficiary Prioritization Process:

### 5.1. Prioritization of beneficiaries

In the current project for reconstruction of rural houses, we can cover all the 2,543 fully damaged houses and 5,429 (54.2629%) of the total 10,005 severely damaged houses (District wise breakup in Table-2). The prioritization of these 5,429 of the total 10,005 severely damaged houses will be done following economic criteria, with preference given to the poorer households. The district level targets will be broken down to the Block and GPU level caps (Phase-1) and selection of poorer households done in a Special Gram Sabha convened specially for this purpose.

**Table 2**

S. No.	Type of damage	North	East	South	West	Total
1	Fully damaged for project	516	956	446	625	2,543
2	Total severely damaged	4,500	3,077	857	1,571	10,005
3	Total severely damaged for project	2,442	1,670	465	852	5,429
4	Total for project (1 + 3)	2,958	2,626	911	1,477	7,972
		37%	33%	11%	19%	100%

In the post earthquake situation, adequate field verification was not feasible as rescue, relief and temporary restoration operations were also in full swing. The purpose of ex-gratia relief payments was to provide immediate relief irrespective of the economic status of the victim/beneficiary since a universal policy was taken. However, incase of house reconstruction the purpose is different, as it is a long term reconstruction, which is taken up after rescue, relief and immediate restoration has been completed, with better planning and detailed field verification. There is a need for criteria to prioritize households whose names figure in the ex-gratia payment list for fully and severely damaged houses. Also prioritization has to be done since 7,972 households have to be selected in Phase-I from the total 12,548 households. The remaining 4,576 (12,548 – 7,972) damaged rural houses have been included in the DPR for the Comprehensive Package and may be taken up in Phase II. These prioritization criteria will serve as a double check on the beneficiary selection made earlier while releasing the ex-gratia payments.

### 5.2. Special Gram Sabha

- **Step01: District level preparatory exercise**

The following preparatory exercise has to be completed from the District level and the following details provided:

- Authorized list of “GPU level fully damaged households” needs to be provided by the District.
- Authorized list of “GPU level severely damaged houses” needs to be provided by the District.
- GPU level Phase-1 Cap of the total fully/severely damaged houses needs to be provided by the District.
- Give 15 days advance notice of this Special Gram Sabha along with mobile public announcement (using vehicle) covering all the GPWs.

- BDO should mandatorily attend this Gram Sabha and preferably SDM/ADM as well.
- **Step02: Prioritizing Phase-I beneficiaries from the fully damaged list**  
In the Special Gram Sabha, the check on the fully damaged houses needs to be done first, where the list of fully damaged households is read out, and those households satisfying any of the 7 criteria shifted to Phase-II. The reason for shifting to Phase-II also needs to be noted in the minutes for each and every Phase-II household.

**Fully damaged houses de-prioritization criteria:** *(shift to Phase-II if any of these 7 criteria is met)*

1. Main dwelling house not fully or severely damaged but only separate kitchen or toilet is damaged.
  2. More than one adult beneficiary has been identified belonging to the same fully or severely damaged house. In this case, all those other than the head of the household need to be excluded.
  3. Non local household.
  4. If the household owns a RCC building, in addition to the house that has been listed as fully/severely damaged.
  5. If any member of the household is a regular government employee, and the household owns more than one house.
  6. Recipients of ex-gratia recipients of Rs 5 lakh for earthquake damaged house reconstruction.
  7. Households that already have a CMRHM house allotted to them which has not been fully/severely damaged.
- The number of fully damaged houses shifted to Phase-II need to be correspondingly increased in the severely damaged category within the same GPU.
  - **Step03: Prioritizing Phase-I beneficiaries from the severely damaged list**  
Following this, the prioritization of severely damaged houses needs to be done using integrated criteria where the list of severely damaged households is read out and the integrated criteria applied for prioritizing the households. The application of these criteria for Phase-1 and Phase-II households needs to be noted in the minutes for each and every household.

**Severely damaged houses integrated criteria:**

*(Shift to Phase-II if any of these 7 conditions is met)*

- 1.1 Main dwelling house not fully or severely damaged but only separate kitchen or toilet is damaged.
- 1.2 More than one adult beneficiary has been identified belonging to the same fully or severely damaged house. In this case, all those other than the head of the household need to be excluded.
- 1.3 Non local household
- 1.4 If the household owns a RCC building, in addition to the house that has been listed as fully/severely damaged.

- 1.5 If any member of the household is a regular government employee, and the household owns more than one house.
- 1.6 Recipients of ex-gratia recipients of Rs 5 lakh for earthquake damaged house reconstruction.
- 1.7 Households that already have a CMRHM house allotted to them, which has not been fully/severely damaged.

*(Shift to Phase-I if any of these 5 conditions is true)*

- 2.1 Local landless households
- 2.2 CMRHM house either completed or under construction has been severely damaged
- 2.3 Main source of income of all members of the household is agricultural or wage labour and the household owns less than one acre of land
- 2.4 Vulnerable households (households with no male member between 18 to 60 years of age, or households where main earning member is physically challenged)
- 2.5 DESME 2010 revised BPL list can be used as reference

**For example: (Table 3)**

In a GPU, there are 20 fully damaged and 50 severely damaged houses. Then the GPU level Phase-1 Cap for the GPU is  $(20 + 0.54 \times 50) = (20 + 27) = 47$ . First de-prioritization is followed on fully damaged houses, and let us say 2 households get de-prioritized. Then we follow the integrated criteria on the severely damaged houses, and let's say 21 households get de-prioritized to Phase-II and 29 prioritized to Phase-I. So a total of 47 households get prioritized in Phase-1 and the remaining 23 households get shifted into Phase-II.

**Table 3**

Category	Initial List of HH	Phase-1 Cap	Criteria results in Special Gram Sabha	Phase-I HH	Phase-II HH
Fully	20 HH	20 HH	2 HH shifted to Phase-II	18	2
Severely	50 HH	27 HH (54% of 50 HH)	21 HH shifted to Phase-II and 29 HH to Phase-I	29*	21
<b>Total</b>	<b>70</b>	<b>47</b>		<b>47</b>	<b>23</b>

\* Note that 29 HH get selected from the Severely Damaged houses through the Phase-I Cap was only 27HH. This is because the 2 HH shifted to Phase-II from the Fully Damaged houses can be correspondingly increased in the Severely Damaged category within the same GPU.

**5.3 Fully and Severely damaged CMRHM houses**

Fully and severely damaged houses of CMRHM which have already been listed in the ex-gratia beneficiary list need to be physically and financially closed, and instead new houses need to be taken up under this reconstruction scheme.

**5.4 Shortfall in achieving Phase-I beneficiary cap**

It is possible that in a few cases, a large number of households may get shifted to Phase-II while applying the criteria on the Fully and Severely damaged houses. In these cases, there will be a

shortfall in achieving the Phase-I cap. In such cases, the shortfall can be met from deserving households of other GPUs.

### **5.5 Finalization of Phase-I beneficiary list**

Fully and severely damaged beneficiaries who get prioritized in the Phase-I beneficiary list need to be finally passed in this Special Gram Sabha. Before passing, the BDO who needs to be personally present in this Special Gram Sabha, needs to ensure that beneficiaries so selected should not exceed the GPU level Phase-I cap. After passing in the Special Gram Sabha, this beneficiary list gets finalized.

### **5.6 Publication of final beneficiary list**

- Within 7 days of the Special Gram Sabha, the final beneficiary list passed in the Special Gram Sabha will be published in the following format - *S. No, District, Block, GPU, GPW, Name of Beneficiary, Father's/Husband's Name, Fully damaged / Severely damaged* and put up in public domain in following places –
  - Gram Prashashan Kendra
  - BDO Office
  - ADC (Dev) Office
  - DCs Office and
  - RM&DDs website
  - REDRH web portal ([www.sikkirmdd.gov.in](http://www.sikkirmdd.gov.in))
- A copy should also be kept in Gram Prashashan Kendra, BAC and offices of ADC(Dev) for official purposes.

## **6. House Construction Process:**

### **6.1 Implementation mechanism**

The Rural Management and Development Department will be the implementing Department for this project, for which Land Revenue and Disaster Management Department is the nodal Department. **The implementation mechanism will be Departmental** to ensure fast grounding and completion of this project which is a relief related NC activity. No contractors or middle men will be permitted.

### **6.2 Issuing Allotment Order to all beneficiaries**

- 6.2.1. Selected beneficiaries whose names figure in the Final Phase-1 Beneficiary List need to apply in the Application Form (Annexure I) in triplicate to the concerned BDO providing details of name, father's/husband's name, gender, age, GPU, GPW, Mobile number along with four passport size photos. This has to be in triplicate, one copy for GPK, one for BAC and one for District with attestation of concerned Panchayat President and RDA. The fourth photo will be affixed in the Allotment Order.
- 6.2.2. Block verifies whether the beneficiary has been finalized in the Special Gram Sabha and his name figures in the Final Phase-I Beneficiary List and the form is complete in all respects before submitting the application to ADC (Dev).
- 6.2.3. The ADC(Dev) and the District Collector on being fully satisfied that the prescribed guidelines have been followed, issue the filled up allotment order complete in all respects to the BAC.

6.2.4. Allotment orders need to be filled up and certified by the ADC and blank Allotment Orders should not issued to the BAC at any cost.

6.2.5. Photocopy of the Allotment order needs to be maintained by the ADC and also provided to the RMDD headoffice on a monthly basis.

6.2.6. The Allotment No. or House No. will be 9 digits having the following breakup namely:

Digits →	1	2	3	4	5	6	7	8	9
Codes →	District Code	Block Code		GPU Code		GPW Code	S. No.		

**District Code: 1 digit** i.e. North = 1, East = 2, South = 3, West = 4

**Block Code: 2 digits** i.e. 01, 02, 03, 04, 05, 06, 07, 08, 09, 10

**GPU Code: 2 digits** i.e. 01, 02, 03 .....

**GPW Code: 1 digit** i.e. 1, 2, 3, 4, 5, 6, 7, 8, 9 .....

**S. No. : 3 digits** i.e. 001, 002, 003, 004, 005, 006, 007, 008, 009, 010 ....

6.2.7. ADC(Dev) needs to ensure that the approved list of beneficiaries are uploaded in the web based MIS of REDRH available at <www.sikkimrmd.gov.in>

6.2.8. The detailed list of final approved beneficiaries (cumulative) needs to be provided on a monthly basis by the ADC(Dev) to the office of the DC and RM&DD headoffice in the following format:

*S. No, District, Block, GPU, GPW, Allotment no (8 digits), Allotment date, Name of Beneficiary, Father's / Husband's Name, Mobile No., Category (fully damaged / severely damaged)*

6.2.9. BDO organizes Orientation Program for all the beneficiaries before handing over the Allotment Orders to them.

6.2.10. Block hands over the Allotment Order and takes the Undertaking (of the beneficiary) in duplicate to the final approved beneficiaries in prescribed format (Annexure II & III).

### 6.3 Stages of house construction

There will be four stages in house construction as follows:

Stages of progress	Pre-requisites for release of funds	Financial installment	Stock materials
<b>Stage-I</b>	Beneficiary selection and issue of Allotment Order	<b>1<sup>st</sup> Installment</b> - Rs 60 thousand as advance to AE	26 quintals of TMT Bar (Rod)
<b>Stage-II</b>	605 square feet of plinth area, with 9 columns should be completed. Both foundation and plinth is complete	<b>2<sup>nd</sup> Installment</b> - To be informed later	
<b>Stage-III</b>	All 9 columns, beams and roof is complete	<b>3<sup>rd</sup> Installment</b> - To be informed later	
<b>Stage-IV</b>	House is complete in all respects	<b>4<sup>th</sup> Installment</b> - To be informed later	

\* Subject to revision of rates of stock material provided by STCS

### 6.4 Release of first financial installment

- 6.4.1. BDO requisitions for pass order and fund release from the ADC (Dev) by providing the list of final approved beneficiaries
- 6.4.2. ADC (Dev) releases funds to meet the 1<sup>st</sup> installment for the final approved beneficiaries to the Block by issuing a pass order
- 6.4.3. BDO provides an advance of Rs 60,000 to the AE, subject to recovery of Rs 20,000 in three equal installments. Sub Vouchers (Annexure IV) for releasing this Advance needs to be filled up per beneficiary with a covering Contingent Bill Form as indicated in Annexure V.
- 6.4.4. It is recommended that, in one lot, advance for more than 20 houses should not be taken out. Only when the earlier advance is exhausted, the next lot should be processed.
- 6.4.5. AE provides an indent of 26 quintal of rod per approved beneficiary to the JE
- 6.4.6. After utilizing 60% of the first installment, the Block becomes eligible for receipt of next installment of funds from the District
- 6.4.7. Necessary updates in the REDRH web based MIS ([www.sikkimrmd.gov.in](http://www.sikkimrmd.gov.in)) needs to be done

Subsequently, release of 2<sup>nd</sup>, 3<sup>rd</sup> and 4<sup>th</sup> installments will also be based on sub-vouchers beneficiary wise with a covering CB at pre-defined stages (Stage II, III and IV), formats of which will be provided for in due course of time.

### **6.5. Convergence**

- (a) Electrification of the house will be provided through Rajiv Gandhi Gramin Vidyutikaran Yojana (RGGVY); For this, concerned AE / JE posted in the BAC shall pursue the matter with concerned Line Departments and gets the work done
- (b) Water supply through National Rural Drinking Water Program (NRDWP)
- (c) Forest Department will either provide timber under the scheme at subsidized rate or issue marking order for extraction of the timber of the standing trees from private land holding.

### **6.6. Information, Education and Communication (IEC) Activities**

Partnership with NGOs like Voluntary Health Association of Sikkim (VHAS), WWF-India and others is being explored to provided awareness, education, training materials and capacity building support on a voluntary (no-cost implication to State Government) basis.

**The Block team needs to take photographs of all the stages of this project to ensure detailed photo documentation of the process followed, outputs created and outcomes generated. Details need to be regularly updated in the Web based MIS ([www.sikkimrmd.gov.in](http://www.sikkimrmd.gov.in)) as well.**

## 7. Financial Management

The Reconstruction of Earthquake Damaged Rural Houses (REDRH) is a 100% Central Assistance under the Prime Minister’s Special Package from the Government of India under the Special Plan Assistance (SPA) of the Planning Commission of India. The program is scheduled to be completed during 2012-13 with a total physical target of 7,972 rural houses involving a total financial investment of Rs 389 crores. The financial management system will be similar to the Chief Minister’s Rural Housing Mission (CMRHM).

### 7.1 Annual physical and financial targets

Rs in lakh

S. No	Key Activity	Technical Details	Unit Cost	2011-12		2012-13		Total	
				Phy	Fin	Phy	Fin	Phy	Fin
1	Reconstruction of Earthquake Damaged House	House of 605 square feet plinth area and RC frame	4.89 Lakh per household	0	4,000	7,972	34,900	7,972	38,900
<b>Total</b>					<b>4,000</b>		<b>34,900</b>		<b>38,900</b>

### 7.2 Fund transfer mechanism

The fund release and transfer mechanism from the State to the District and from the District to the Block will be similar to the Chief Minister’s Rural Housing Mission (CMRHM). At the State level, already a bank account for the Rural Housing Scheme is functional in the State Bank of Sikkim which is operated by the Project Director (RHS). At the District level, in order to avoid mixing with ongoing Rural Housing programs, a new bank account will be opened to be operated jointly by the concerned District Collector and the ADC (Development). However, at the Block level, bank accounts need to be opened (if not existing) solely for this Scheme and operated jointly by the BDO and AO. Funds will be released in advance from the State to the Districts and from District to Blocks from where the **payments will be released directly to the AE** after taking mandatory pass order from the concerned ADC(Dev). After utilizing 60% of the available funds, the concerned Block and District can request for release of additional funds. This request has to be accompanied by a Utilization Certificate (Annexure VI) and Monthly Progress Report (Annexure VII).



### **7.3 Fund release and record keeping**

The implementation mechanism is Departmental, no contractors are permitted. The total cost of the work is Rs 4.89 lakh including stock material. Fund can be drawn in four stages of the work viz; advance, plinth level, roof level and on completion of the work. The BAC shall maintain the separate cash book, beneficiary's work register, CAR and bill register for the reconstruction of earthquake damaged houses. For the withdrawal of advance, sub voucher of REDRH (Format provided in Annexure IV) shall be prepared. The sub-voucher and the CB will be certified by the concerned JE, AE and BDO and will be accompanied by stage-wise photograph of the beneficiary along with the new house under construction. The sub voucher number will be taken from the Beneficiary's Work Register and shall be submitted to the Accounts Section of BACs who shall further prepare the Contingent Bill on the basis of certified aforementioned sub vouchers and withdraw the amount in favour of A.E. BAC. The contingent bill will contain the voucher no. of the cash book. The prescribed books of accounts shall be maintained in chronological order and the BAC shall produce to Audit for scrutiny as and when required. Final payment will be released only after obtaining pass order from the District Collector. All these Books of Accounts will be maintained in chronological order in the BAC for Audit purposes.

After issue of Allotment Order, an Advance of Rs 60,000 per approved beneficiary will be released to the AE, subject to recovery in three equal installments of Rs 20,000 each. Sub Vouchers (Annexure IV) for releasing this Advance needs to be filled up per beneficiary with a covering Contingent Bill Form as indicated in Annexure V.

Subsequently, release of 2<sup>nd</sup>, 3<sup>rd</sup> and Final installments will also be based on sub-vouchers beneficiary wise at pre-defined stages with a covering CB, formats of which will be provided for in due course of time.

### **7.4. Financial Audit by chartered accountant**

Financial Audit by chartered accountant is mandatory. This must be carried out at the end of the financial year by each District. The audit will be done by the Chartered Accountants and a copy of the Audit report needs to be sent to the head office by 15<sup>th</sup> May of the next Financial Year.

### **7.5. CAG Audit**

The Office of the Accountant General may also conduct the Audit of Accounts in addition to the audit conducted by the Chartered Accountant. The audit team of the Accountant General shall be supplied with a copy of the audit conducted by the Chartered Accountants.

## **8. Records to be maintained**

The Block and District needs to maintain the following files and registers

### **8.1 FILES**

#### **8.1.1 Block Level (3 files)**

- 1. Beneficiary Master File (GPU wise):** Gram Sabha resolution, Ward Sabha resolutions, Approved list of beneficiary, Beneficiary Application form, Allotment Order

(photocopy), Undertaking, Completion Report, Handing-Taking report and other documents pertaining to the beneficiary

2. **Monitoring File:** Containing the verification reports, inspection reports etc
3. **MPR file:** Containing all the MPRs of physical and financial performance and Utilization Certificates
4. **Others as per need**

#### 8.1.2 District Level (3 files)

1. **Beneficiary Master File:** Containing the Allotment Order (photocopy)
2. **Monitoring file:** verification reports, inspection reports etc
3. **MPR file:** Containing all the MPRs of physical and financial performance and utilization certificates
4. **Others as per need**

### 8.2 REGISTERS

#### 8.2.1 Block Level (4 registers)

1. **Separate Cash Book** (in standard format)
2. **Contingent Audit Register** (in standard format)
3. **Beneficiary Works Register (Block wise): Details of one beneficiary in one page**

##### 3.1 Beneficiary details

S. No., House No., Name of Beneficiary, Fathers/Husbands name, GPW, Mobile no, Value of the Work, Date of allotment

##### 3.2 Payment details

Release of 1<sup>st</sup> Installment - Advance (Amount, Date and Sub-Voucher No.),

Release of 2<sup>nd</sup> Installment (Amount, Date and Sub-Voucher No.),

Release of 3<sup>rd</sup> Installment (Amount, Date and Sub-Voucher No.),

Release of Final Installment (Amount, Date and Sub-Voucher No.)

##### 3.3 Completion details

Date of completion, Date of handing over to beneficiary

Affix photo of new house with the beneficiary

4. **Bill Register** (in standard format)
5. **Others as per need**

#### 8.2.2 District Level

1. **Separate Cash Book** (in standard format)
2. **Cheque Issue Register** (in standard format)
3. **Others as per need**

## 9. Monitoring and Evaluation

The monitoring and evaluation mechanism at the Block, District and State level is as follows:

### 9.1 Village level

Village Level Committee (VLC) with Gram Panchayat President as the Chairperson, other Ward Panchayats as Members and RDA as the Member Secretary.

### **9.2 Block level**

The existing Block Rural House Construction Committee (BRHCC) which has been constituted under the Chief Minister’s Rural Housing Mission (CMRHM) will also supervise this program. This committee will function under the chairmanship of the concerned local area MLA, line department officers as Members and BDO as Member Secretary. The composition of this committee is as follows:

- |                                     |   |                  |
|-------------------------------------|---|------------------|
| 1. Concerned Area MLA               | : | Chairman         |
| 2. Concerned Panchayat President    | : | Member           |
| 3. Concerned Zilla Panchayat member | : | Member           |
| 4. Concerned Ward Panchayat         | : | Member           |
| 5. Concerned A.E. (Civil)           | : | Member           |
| 6. Concerned A.E. (Electrical)      | : | Member           |
| 7. Concerned ACF                    | : | Member           |
| 8. Concerned A.O./Acct              | : | Member           |
| 9. Concerned BDO                    | : | Member Secretary |

This committee will oversee the implementation of this project.

### **9.3 District level**

District Level Committee headed by District Collector with ADC (Development) as member secretary, AD/CAO of District Pay and Accounts, DE Zilla, DFO(T) and DE(Power) as members. The DC may co-opt other members into this committee based on need.

### **9.4 State level**

State Level Committee with Special Secretary, Chief Engineer, Additional Chief Engineer, AD(Accounts) as members and Additional Secretary as the member convenor. Also 15 officers from RMDD, SRDA, SREDA and SIRD to be made responsible for monitoring 2 Blocks each atleast on a monthly basis and submit their report to the Secretary-RM&DD. They will be designated as State Level Monitors (SLM).

### **9.5 Inspection:**

Field visits, inspections and sample checks (internally and externally) must be undertaken on a regular basis to ensure comprehensive and continuous assessment of the Scheme. It is mandatory to complete atleast 100% inspection by the Village level, 100% by the Block level, 25% by District level and 10% by State level. Inspection reports should be accompanied by photographs of the inspecting authority along with the house and the concerned beneficiary. Inspection should cover not only the physical progress of the house but also record keeping.

### **9.6 Progress Reporting:**

Monthly Progress Report indicating the physical and financial performance in prescribed format (Annexure VII) needs to be provided by the Block to the District before 5<sup>th</sup> of the next month and by the District to the State before 10<sup>th</sup> of the next month. Online MPR will also be attempted in an online web-based MIS created with the support of IT-Department inhouse in which all the details of this project will need to be uploaded from the Block and District level. The online MIS

will be along the lines of MGNREGA, wherein the progress reports at village, block, district and state level will be available.

### **9.7 Complaints and grievance redressal:**

The Grievance Redressal Officer at the GPU level is the Gram Panchayat President, at the Block level is the BDO and at the District level is the ADC(Dev). Complaints/Grievances against GPU level have to be placed at Block level, against the Block level have to be placed at District level and against the District level have to be placed in RM&DD head office. The Grievance Redressal Officer shall normally dispose off the complaints/grievances within the prescribed time period of 15 days. The complaints/grievances have to be submitted in written by the applicant under his/her signature, and the Grievance Redressal Officer shall provide a dated and signed receipt of the same.

In order to preempt complaints, grievances and communication gap, the Block shall organize Bi-monthly Coordination Meetings (BCM) with all the beneficiaries.

### **9.8 Transparency safeguards:**

- Beneficiary selection following a transparent process of initial ex-gratia list, cross checked and prioritized following a transparent criteria in Special Gram Sabha, followed by public display
- All fund releases after achieving pre-fixed milestones
- Centralized purchase of stock material at an institutional price to ensure quality construction material at cheaper than market prices
- Quality of stock material ensured pre-specified i.e. approved brands for Cement will be Lafarge, Birla, Jayapee and Ambuja
- Rod will be of technical specification TMT Bar 500d with earthquake resistant specifications
- Double entry of stock materials with entry made on the allotment order provided to the beneficiary
- Internal inspections and monitoring at Block, District and State level
- Financial Audit by Chartered Accountant (CA)
- Audit by office of Accountant General (AG)
- Monthly physical and financial reporting system
- Online web based MIS to keep close track of the project

## **10. Capacity Building**

### **10.1 Administrative trainings**

Administrative trainings covering Chapters 1, 2, 3, 5, 6, 8, 9, 10 and 11 will be conducted for all the Block and District level personnel from the State level. Following this the BAC needs to organize orientation trainings for the Gram Panchayat level functionaries.

### **10.2 Accounts trainings**

Accounts related trainings covering Chapters 6, 7, 8 and 9 will be conducted for all the Block and District level personnel from the State level. Following this the BAC needs to organize orientation trainings for the Gram Panchayat level functionaries.

### 10.3 House construction technical trainings

These technical trainings will have a practical session and will cover Chapters 4, 6 and 9.

## 11. Activity Calendar

### 11.1 District, Block and Gram Panchayat level

S. No.	Activity	Responsible Officer	Supervising Officer	Deadline
1	Prepare the <b>Initial List</b> of fully and severely damaged house beneficiaries based on the ex-gratia payments released in consultation with LR&DMD	District Collector	Secretary-LR&DMD	5 <sup>th</sup> April, 2012
2	Calculate the GPU level Phase-1 caps (fully damaged + 54% of the severely damaged houses) such that the overall district level Phase-1 caps are not exceeded. The District level Phase-1 caps are as follows: North – 2958 East – 2626, South – 911 and West – 1477	District Collector	Secretary-LR&DMD	5 <sup>th</sup> April, 2012
3	Give wide publicity of the Special Gram Sabha atleast 7 days in advance along with mobile announcement covering all the Gram Panchayat Wards of the GPU	BDO	ADC(Dev)	9 <sup>th</sup> April, 2012
4	Special Gram Sabhas to be held during	BDO	ADC(Dev)	16 <sup>th</sup> April to 25 <sup>th</sup> April, 2012
5	Special Gram Sabhas to be completed and final Phase-1 beneficiary list to be publicized	BDO	ADC(Dev)	30 <sup>th</sup> April, 2012
6	Phase-1 beneficiaries fill up Application Form (Annexure-I) and apply to BDO	BDO	ADC(Dev)	10 <sup>th</sup> May, 2012
7	ADC(Dev) fills up the Allotment Orders, indicates the House No / Allotment No (9 digits) and forwards to the BAC for handing over to the beneficiary	ADC(Dev)	District Collector	15 <sup>th</sup> May, 2012
8	Organizing Orientation Program of beneficiaries before handing over the Allotment Orders to them and	BDO	ADC(Dev)	15 <sup>th</sup> - 20 <sup>th</sup> May, 2012
9	Initiation of house construction	BDO	ADC(Dev)	21 <sup>st</sup> May, 2012
10	Forwarding of final list of Phase-I beneficiaries to RM&DD head office in	ADC(Dev)	District Collector	1 <sup>st</sup> June, 2012

	format as prescribed in Para 6.1.8			
11	Submission of MPRs to RM&DD head office in Annexure VII	ADC(Dev)	District Collector	By 10 <sup>th</sup> of every month
12	Organize Bi-monthly Coordination Meetings (BCM) with all the owners to preempt complaints and grievances	BDO	ADC(Dev)	6 times in a year

### 11.2 RM&DD head-office level

S. No.	Activity	Responsible Officer	Supervising Officer	Deadline
1	Notifying the institutional mechanism for the new program in head office			Completed
2	Preparatory meeting with STCS regarding centralized purchasing of stock material			Completed
3	Preparing the draft operational guidelines jointly with Engineering Wing			Completed
4	Discussion of the draft Operational Guidelines with MLAs, line departments, District and Block officials	Consultations held on 10 <sup>th</sup> Jan, 2012, 20 <sup>th</sup> Feb, 2012 and 16 <sup>th</sup> March, 2012		Completed
5	Advance information to the Districts to initiate preparatory work			Completed
6	Obtain PI from TMT bars from STCS			Completed
7	Prepare the customer requirement for the online web based MIS and preparatory meeting with DIT	Meeting with DIT held on 28 <sup>th</sup> March, 2012 and Official letter also sent		Completed
8	Finalization and circulation of the Operational Guidelines	4 <sup>th</sup> April, 2012		Completed
9	Obtaining cabinet approval of the Implementation Plan	19 <sup>th</sup> April, 2012		Completed
10	Training of District and Block level teams on operational guidelines	28 <sup>th</sup> April, 2012		Completed
11	Finalizing the printing of all Forms / Annexure Finalizing the REDRH Web based online software			

**Annexure I**

**APPLICATION FORM**

**For Grant of Reconstruction of Earthquake Damaged Rural House**

*(In Triplicate)*

**To,**  
**The Block Development Officer,**  
**Block.....**

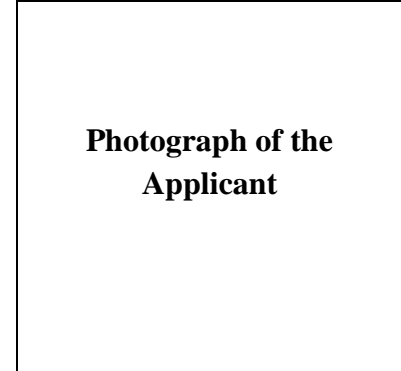

**Subject: Reconstruction of Earthquake Damaged Rural House**

Sir/Madam,

I, Smt/Shri ..... resident of  
.....(name of Ward/GPU) request you to kindly grant  
me a Reconstruction of Earthquake Damaged Rural House, as my original house got  
fully/severely damaged in the earthquake of 18<sup>th</sup> Sept, 2011.

**My particulars are as under:-**

1. Husband's / Father's Name : \_\_\_\_\_
2. Permanent Address : \_\_\_\_\_
3. Gram Panchayat Unit : \_\_\_\_\_
4. Ward: \_\_\_\_\_ 5. District: \_\_\_\_\_
6. Mobile no : \_\_\_\_\_
7. Category of beneficiary (ST/SC/MBC/OBC/Other): \_\_\_\_\_
8. Attested Copy to be enclosed : Sikkim Subject Certificate of Identification/ Land Parcha.

Yours faithfully,

**Date**.....

Name/Signature/Thumb Impression  
of the applicant

**Attested by concerned Panchayat President  
and RDA**



**Annexure II**

**RURAL MANAGEMENT AND DEVELOPMENT DEPARTMENT  
GOVERNMENT OF SIKKIM**

**ALLOTMENT ORDER** *(In Original Only)*

*(Separate pre-printed forms will be provided from head office)*

**Allotment No:** .....

**Date**.....

*(House No = 9 digits)*

**To,**

.....(Name of beneficiary)

.....(Block)

.....(GPU)

.....(Ward)

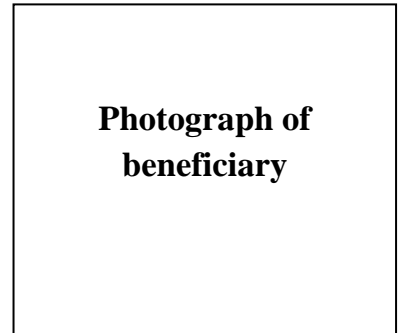

**Photograph of  
beneficiary**

**Subject: Allotment of Reconstruction of Earthquake Damaged Rural House (REDRH)**

I am directed to inform you that the Government of Sikkim has sanctioned the Reconstruction of Earthquake Damaged Rural House in your favour, subject to following terms and conditions:

1. House of value Rs. 4.89 lakh (including the cost of stock materials) to be provided by RM&DD.
2. The design of the house will be as follows:
  - **Size:** Plinth area should not be less than 605 sq feet
  - **Foundation:** RCC with 9 columns (1feet x 1 feet) and RCC beams of (1feet x 1 feet)
  - **Walls:** should be half brick walling over RCC frame
  - **Flooring:** should be Cement Concrete
  - **Roofing:** RCC Slab 4 inches thick. *Chajja* or cantilever has projection of 2 feet 9 inches
  - **Sanitation:** One toilet with septic tank
3. The house should be preferably constructed in the same location as the fully/severely damaged house, unless the site is unstable and not suitable for house construction.
4. The beneficiary shall provide land for the construction of the REDRH house and also assist to supervise the construction.
5. The beneficiary will contribute local material (stone, sand, timber etc) from the damaged house and also self labour to the extent possible.
6. Once the house construction is completed, the beneficiary will undertake to take over the same from RM&DD and assume responsibility of future maintenance and repair.

..... (Name of District)

**Signature of ADC (Development)**



**Annexure III**

**UNDERTAKING**

*(In Duplicate Only)*

Reference Allotment Order No: ....., Dated ....., this undertaking is made on the day..... of.....2012 that I, Shri/Smt/Miss ..... son of / wife of / daughter of ..... resident of .....Ward, ..... GPU shall provide land for the construction of the REDRH house and also assist to supervise the construction as per the **house design** indicate below:

- **Size:** Plinth area should not be less than 605 sq feet
- **Foundation:** RCC with 9 columns (1feet x 1 feet) and RCC beams of (1feet x 1 feet)
- **Walls:** should be half brick walling over RCC frame
- **Flooring:** should be Cement Concrete
- **Roofing:** RCC Slab 4 inches thick. *Chajja* or cantilever has projection of 2 feet 9 inches
- **Sanitation:** Minimum one toilet along with septic tank

I will contribute local material (stone, sand, timber etc) from the damaged house and also self labour to the extent possible. Once the house construction is completed, I undertake to take over the same from RM&DD and assume responsibility of future maintenance and repair at my own expense.

**Signature of Beneficiary** .....

**Name of Beneficiary** .....

**Ward Name** .....

**GPU name** .....

**Mobile No.** .....

**Witness:- (Signature and Name)**

1. ....

2. ....

**SUB VOUCHER FORM**

**Sub Voucher No:** \_\_\_\_\_

**Date:** \_\_\_\_\_

**Release of Advance towards REDRH - Project**

**(I) Beneficiary details**

Name of Beneficiary.....

Father's / Husband's Name .....

House No:.....

Ward Name.....

GPU name .....

Mobile No. ....

**(II) Total value of work** : Rs. 4.89 lakh including Stock Materials

Advance: Rs 60, 000.00 (Rupees Sixty Thousand) only

Certified that the advance has been drawn as per the REDRH Operational Guidelines towards the above mentioned House subject to recovery in three installments @ Rs.20,000/- per installment. The amount has been entered in **Beneficiary Work Register** vide Page No. \_\_\_\_\_.

**Signature** \_\_\_\_\_

**Name** \_\_\_\_\_

**(BDO)**

**(AE)**

**(JE)**

**CONTINGENT BILL FORM**  
**(Original Green Colour Form to be used)**

(To be filled in duplicate, with duplicate copy to be sent to ADC(Dev) on a monthly basis)

**Bill no-**  
**Date-**

**CASH BOOK**  
**Vr no -**  
**Date-**

Sub-Voucher	Head Of Account	Amount (Rs)
	(Remember to indicate the entire house nos of the enclosed sub vouchers)	

Allotment for the current year per BAC Rs \_\_\_\_\_

Expenditure including this Bill Rs \_\_\_\_\_

Balance available RS \_\_\_\_\_

Certified that D.c Bills for all contingent bills for advance drawn more than three months before have been submitted to the Accountant General.

**Signature and designation of Drawing Officer of BAC**

Cheque no \_\_\_\_\_

Dt \_\_\_\_\_

Received by AE \_\_\_\_\_ BAC



**Annexure VI**

**RURAL MANAGEMENT AND DEVELOPMENT DEPARTMENT  
GOVERNMENT OF SIKKIM  
GANGTOK**

**NO:** ..... /BAC/

**Date**.....

**60% Fund Utilization Certificate**

This is to certify that for the “**Reconstruction of Earthquake Damaged Rural Houses**” out of Rs..... received vide letter No:..... Dated..... under the against this 60% of fund i.e. Rs..... has been utilized so far and therefore requested to release of next installment.

**ADC (DEV) / BDO**

**or**

**District / BAC**

**Reconstruction of Earthquake Damaged Rural Houses**  
**Monthly Progress Report**  
*(Sample Format)*

**Part -1: Physical Performance** (cumulative)

Financial Year: \_\_\_\_\_ Upto the Month: \_\_\_\_\_

1	2	3			4	5
		a	b	c		
District	Total houses sanctioned	Houses taken up				Total
		Ongoing			Completed	
		In Stage-I	In Stage-II	In Stage-III	Final Stage	
East	500	100	50	100	150	400

**Part -II: Financial Performance** (cumulative)

Financial Year: \_\_\_\_\_ Upto the Month: \_\_\_\_\_

*Rs in lakh*

1	2	3	4	5	6	7			
						a	b	c	d
District	Opening balance as on 1 <sup>st</sup> April	State release during current year	Central release during current year	Misc. receipt	Total availability	Cumulative expenditure			
						Funds released to AE	Administrative	Total	
East	50.00	0.00	1000.00	5.00	1055.00	1000.00	2.00	1002.00	

## BENEFICIARY WORKS REGISTER

### (I) Beneficiary details

Name of Beneficiary.....  
Father's / Husband's Name .....  
House No (9 digits):.....  
Ward Name.....  
GPU name .....  
Block name .....  
Mobile No. ....

### (II) Payment details

#### Release of 1<sup>st</sup> Installment - Advance

Total value of work done .....  
Net release .....  
Cheque no .....  
Date: .....

#### Release of 2<sup>nd</sup> Installment

Total value of work done .....  
Advance adjustment .....  
Deduction if any .....  
Net release .....  
Cheque no .....  
Date: .....

#### Release of 3<sup>rd</sup> Installment

Total value of work done .....  
Advance adjustment .....  
Deduction if any .....  
Net release .....  
Cheque no .....  
Date: .....

#### Release of Final Installment

Total value of work done .....  
Advance adjustment .....  
Deduction if any .....  
Net release .....  
Cheque no .....  
Date: .....

**(III) Completion details**

Date of completion .....

Date of handing over to beneficiary .....

Signature of beneficiary .....

**Affix photo of new REDRH house with the beneficiary**